

Structural Connections  
Corbel Replacement

**Leviat**<sup>®</sup>  
A CRH COMPANY

## MB Rapid-Lok<sup>®</sup> Ultimate

The ultimate alternative to concrete corbels

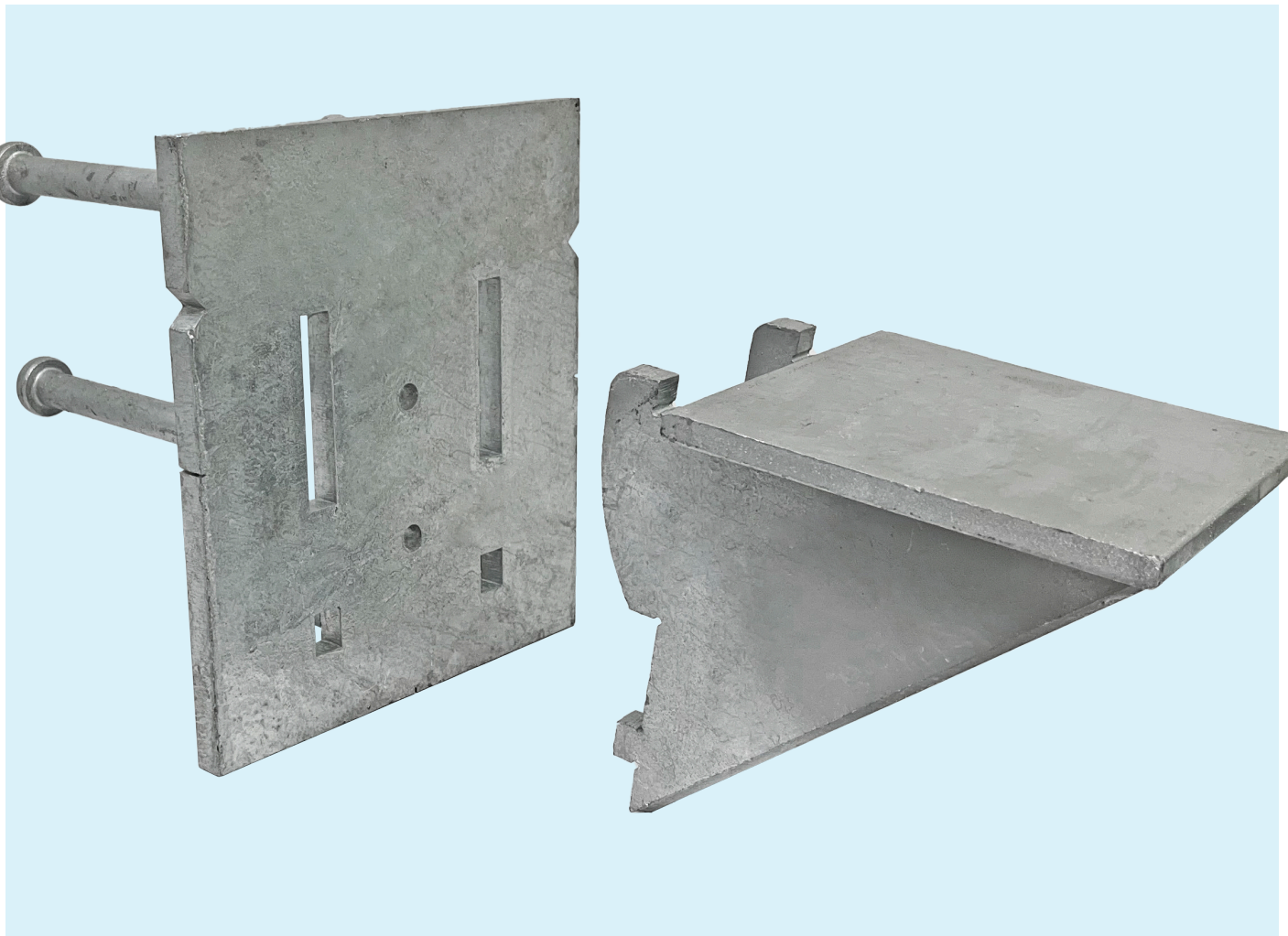

Leviat is the home of:

**MB** MeadowBurke

**H**  
HALFEN

**thermomass**<sup>®</sup>

Imagine. Model. Make.

US PATENT NO. 10,883,265

We imagine, model and make engineered products and innovative construction solutions that help turn architectural visions into reality and enable our construction partners to build better, safer, stronger and faster.

## Our areas of expertise:

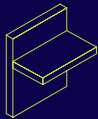

### Structural Connections

Systems to form robust, efficient connections, and continuity of concrete reinforcement as necessary, between walls, slabs, columns, beams and balconies, providing structural integrity as well as enhanced thermal and acoustic performance.

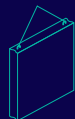

### Lifting & Bracing

Systems for the safe and efficient transportation, lifting and temporary bracing of cast concrete elements and tilt-up panels before permanent structural connections are made.



### Façade Support & Restraint

Systems for the safe and thermally-efficient fixing of the external building envelope, including brick and natural stone, insulated sandwich panels, curtain walling and suspended concrete façades, and also the repair and strengthening of existing masonry installations.



### Anchoring & Fixing

Systems for fixing secondary fixtures to concrete, including anchor channels, bolts and inserts; also tension rod systems for roofs and canopies.



### Formwork & Site Accessories

Non-structural accessories that complement our engineered solutions and help keep your construction environment operating safely and efficiently, including molds for casting standard and special concrete elements and construction essentials such as reinforcing bar spacers.

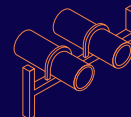

### Industrial Technology

Mounting channels, pipe clamps and other versatile framing systems that provide safe fixing in a wide range of industrial applications.

---

## Leviat product ranges:

Ancon | Aschwanden | Connolly | Halfen | Helifix | Isedio | Meadow Burke | Modersohn | Moment | Plaka | Scaldex | Thermomass

# Traditional Corbel Hurdles

## Concrete Corbel Challenges

The use of traditional concrete corbels presents challenges that complicate production, impede overall quality, and affect the long-term safety and durability of critical load-bearing applications such as those in parking garages.



### Labor-intensive Operations

- Multiple concrete pours
- Complex rebar detailing
- Manual handling

Manufacturing concrete corbels is often labor-intensive and costly, requiring the handling of heavy concrete elements. Critical safety measures are essential and add complexity and expense to the process.

### Costly Secondary Forming

- Special forming required
- Additional dunnage
- Irregular shapes

Casting traditional corbels requires specialized equipment, forms and procedures. Concrete mix, curing times, and environmental conditions must be controlled to meet quality metrics and structural standards.

### Inefficient Storage & Handling

- Cracking concerns
- Obstacles to erection
- Costly repair

Storing and shipping walls and columns with incorporated corbels is also a challenge. These protruding elements often become obstacles and make the erection process more complex.

## MB Rapid-Lok® Ultimate



provides solutions to these issues plus a host of other benefits!

RLU-8

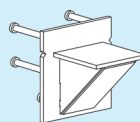

RLU-10

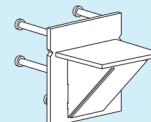

RLU-M

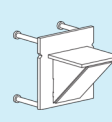

RLU Saddle

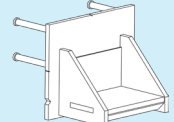

Available in four configurations

# MB Rapid-Lok Ultimate

## Overview

Leviat's MB Rapid-Lok Ultimate is an engineered steel corbel system that provides a permanent, durable, easy-to-install replacement for traditional concrete corbels and welded angles.

Rapid-Lok Ultimate is available in several sizes and capacities to support a variety of load-bearing elements, including double tees and precast stairs.

Installation is safe and simple. The Embed Plate is cast into the concrete column or panel at the precast plant with the face flush to the wall surface. Once the unit is on-site, the attached void formers are removed from the face of the embed plate to reveal recesses. The Bearing Angle ears are then engaged into the recesses of the Embed Plate, securely locking the entire assembly into place without requiring a weld.

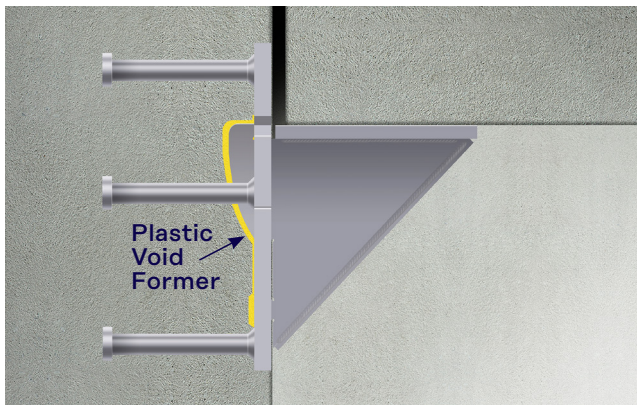

US PATENT NO. 10,883,265

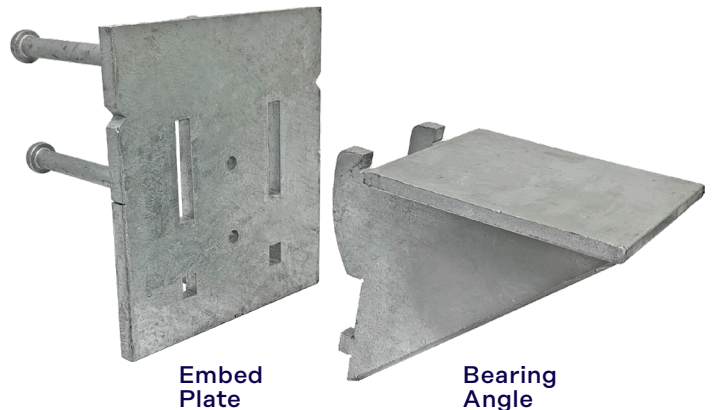

## Benefits

### ■ Structural Engineers

- Capacity rating using LFRD methodology
- Consolidation of models and capacity ranges for simpler design selection
- Load tested to ACI-318's 5% fractile to meet current code requirements
- Fire rating per ASTM-E119 and CAN/ULC-S101

### ■ Double Tee Producers

- Labor efficiencies from simplified panel forming
- Safety improvements by minimizing the risk of injuries
- Cost reductions in transportation and dunnage

### ■ Erectors

- More efficient installation by avoiding obstructions from preinstalled concrete corbels
- Lightweight Bearing Angle securely engages without requiring weld

### ■ Architects and Consultants

- Fluid feature in the finished structure emulating a concrete cast corbel
- Discreet projection with a HDG finish
- Eliminates potential cracking problems with traditional concrete corbels

## Embed Plate & Bearing Angle

The Rapid-Lok Ultimate Embed Plate and Bearing Angle are manufactured from ASTM A572 and A36 steel. They have a hot-dip galvanized finish per ASTM A153.

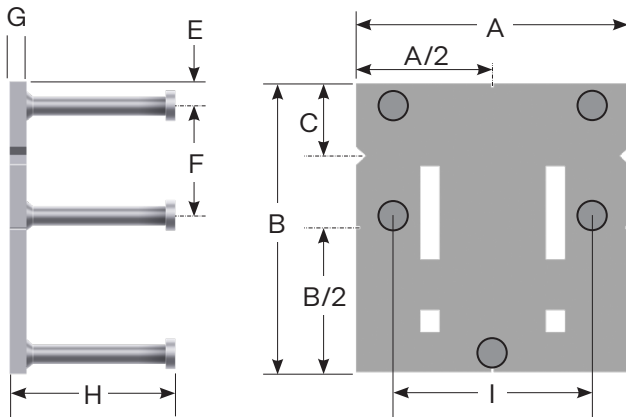

**RLU-8 & RLU-10**

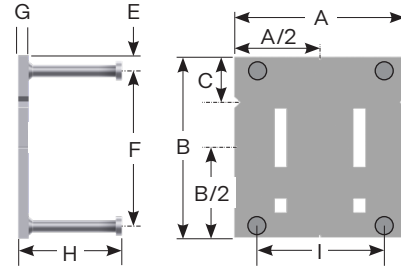

**RLU-M**

### Dimensions - Embed Plate

Product	Item Number	A	B	C*	E	F	G	H	I	Number of Studs	Stud Size	Weight
RLU-8 & RLU-10	MBRLUP8G	11"	12"	3"	1"	4.50"	0.63"	6.81"	9"	5**	0.75"x6.13"	26 lbs
RLU-M	MBRLUPMG	6"	6"	1.63"	1"	4"	0.50"	5.69"	4.50"	4	0.50"x5.19"	6 lbs

\*Tri-cut at dimension C indicates the bearing surface of the angle.

\*\*5th stud is non-structural; it provides stability during up-in-form installation.

### Dimensions - Bearing Angle

Product	Item Number	J	K	L	Weight
RLU-8	MBRLUA8G	8.40"	8"	8"	25 lbs
RLU-10	MBRLUA10G	8.40"	10"	8"	26 lbs
RLU-M	MBRLUAMG	4.11"	4"	4"	5 lbs

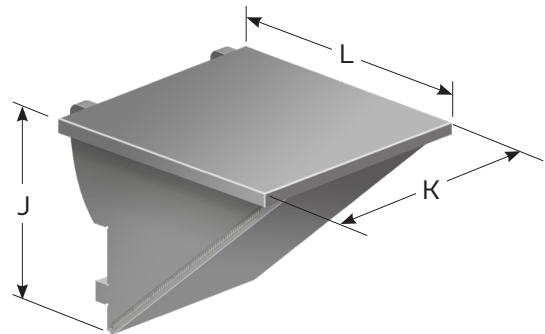

### Quality Assurance

- **100% Dimensional Inspection:** Every unit undergoes rigorous dimensional checks to ensure compliance to specifications.
- **Full Traceability:** Each product is individually marked, ensuring all quality records are accessible.
- **Material & Strength Testing:** Our products undergo comprehensive testing to guarantee optimal performance and durability.

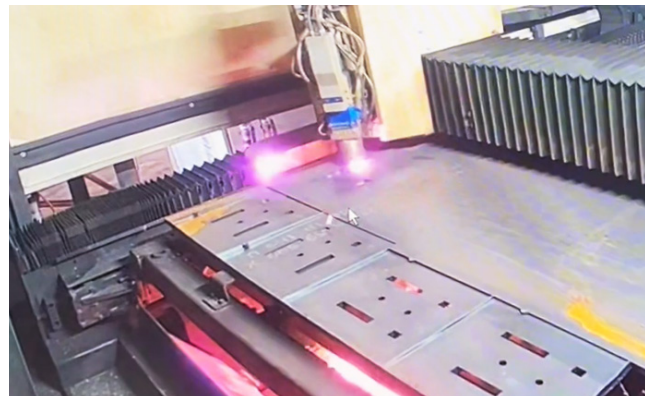

# RLU-8 & RLU-10 Panel Fully Supported at Bottom

Wall, Lite Wall, Column

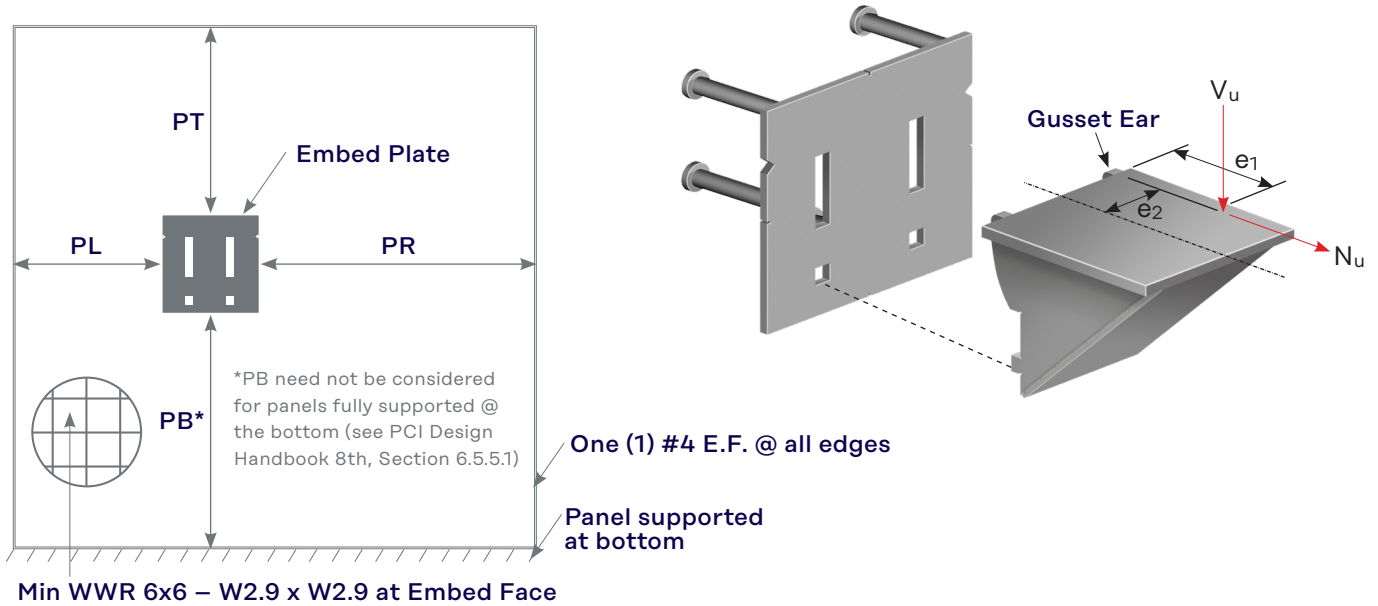

## RLU-8 & RLU-10 Capacities

Table values are based on physical tests using ACI's 5% Fractile Analysis and ACI 318 calculations. **Minimum member thickness = 8"**

1. Tabulated capacities must be coordinated with applicable support conditions
2. ASTM E119 fire duration for all assemblies is 3 hrs with  $V_{service} = 30$  kips
3. Tables are only to be used by qualified structural engineers who understand and apply all applicable codes
4. Table values apply to fully factored ultimate loads ( $V_u$  and  $N_u$ )

Condition	Description	PL	PR	PT	PB	RLU-8 $e_1 \leq 6"$ and $e_2 \leq 2"$			RLU-10 $e_1 \leq 6"$ and $e_2 \leq 3"$		
						$\Phi V_n^{a,b,c}$	$\Phi N_n^{a,b,c,d}$	Failure Mode	$\Phi V_n^{a,b,c}$	$\Phi N_n^{a,b,c,d}$	Failure Mode
BES 1	Not near a free edge	$\geq 9.5"$	$\geq 9.5"$	$\geq 9"$	N/A	42.1 kips	5.3 kips	Steel	42.1 kips	5.3 kips	Steel
BES 2	Free edge on two sides	$\geq 6.5"$	$\geq 6.5"$	$\geq 9"$	N/A	42.1 kips	5.3 kips	Steel	39.4 kips	4.9 kips	Concrete
BES 3	Free edge on one side	$\geq 2"$	$\geq 9.5"$	$\geq 9"$	N/A	37.8 kips	4.7 kips	Concrete	32.4 kips	4.1 kips	Concrete
BES 4	Top edge	$\geq 19"$	$\geq 19"$	$\geq 3"$	N/A	28.6 kips	3.6 kips	Concrete	27.1 kips	3.4 kips	Concrete

- A. Capacity values table BES use a  $\Phi$ -factor = 0.70  
 If the structural engineer determines a  $\Phi = 0.75$  may be used, then the table values may be multiplied by a factor =  $(0.75/0.70) = 1.071$ , **but  $\Phi V_n$  must not exceed the bearing angle's steel capacity of 42.1 kips.** Typical ACI 318  $\Phi$ -factors are: (Reference ACI 318-14 Section 17.3.3)  
 $\Phi$ -factor = 0.70 for members without confinement reinforcing  
 $\Phi$ -factor = 0.75 for members with adequate confinement reinforcing
- B. All values apply to  $f'_c = 5000$  psi. Concrete capacity values may be modified by  $\sqrt{f'_c/5,000}$  psi, **but  $\Phi V_n$  must not exceed the bearing angle's steel capacity of 42.1 kips.** Steel capacity includes  $\Phi = 0.90$
- C. Capacity values for concrete failures may be increased by adding additional reinforcing, (Reference ACI 318-14 Section 17.4.2.9 and 17.5.2.9), **but  $\Phi V_n$  must not exceed the bracket's steel capacity of 42.1 kips.**
- D. Tested values  $N_u$  are based on 12.5% of  $V_u$ . The test loads were applied simultaneously
- E. **For conditions not covered within the tabulated values, connection capacities may be determined using appropriate stud design software or in accordance with the provisions of ACI 318. In all cases, the calculated capacity shall not exceed the steel capacity of 42.1 kips.**

# RLU-8 & RLU-10 Panel with Free Edge at Bottom

Spandrel, Wall Opening Below

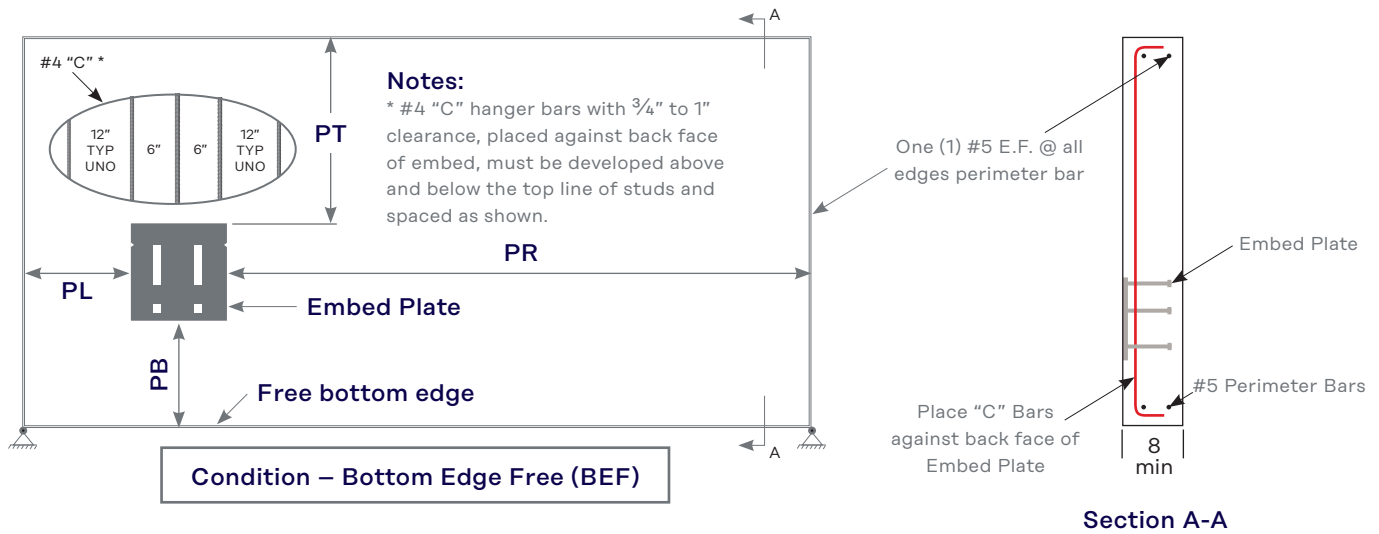

## RLU-8 & RLU-10 Capacities

Table values are based on physical tests using ACI's 5% Fractile Analysis and ACI 318 calculations. **Minimum member thickness = 8"**

1. Tabulated capacities must be coordinated with applicable support conditions
2. ASTM E119 fire duration for all assemblies is 3 hrs with  $V_{service} = 30$  kips
3. Tables are only to be used by qualified structural engineers who understand and apply all applicable codes
4. Table values apply to fully factored ultimate loads ( $V_u$  and  $N_u$ )

						RLU-8 $e_1 \leq 6"$ and $e_2 \leq 2"$			RLU-10 $e_1 \leq 6"$ and $e_2 \leq 3"$		
Condition	Description	PL	PR	PT	PB	$\Phi V_{nf}$ a,b,c,d	$\Phi N_{nf}$ a,b,c,d,e	Failure Mode	$\Phi V_{nf}$ a,b,c,d	$\Phi N_{nf}$ a,b,c,d,e	Failure Mode
"C" Bars	BEF 8 Bottom Edge	$\geq 22.5"$	$\geq 22.5"$	$\geq 9"$	$\geq 4.5"$	41.1 kips	5.1 kips	Concrete	36.4 kips	4.6 kips	Concrete
	BEF 9 Side Edge-Bottom Edge	$\geq 12.5"$	$\geq 22.5"$	$\geq 9"$	$\geq 4.5"$	40.8 kips	5.1 kips	Concrete	36.2 kips	4.5 kips	Concrete
	BEF 10 Bottom Edge	$\geq 22.5"$	$\geq 22.5"$	$\geq 9"$	$\geq 3"$	30.0 kips	3.7 kips	Concrete	26.5 kips	3.3 kips	Concrete
#6 Hairpin (see detail A)	BEF 11 Bottom Edge Reinforced	$\geq 9"$	$\geq 9"$	$\geq 9"$	$\geq 2.5"$	39.7 kips	4.96 kips	Concrete	39.7 kips	4.96 kips	Concrete

- A. Capacity values use a  $\Phi$ -factor = 0.75 due to use of confinement reinforcement
- B. All values apply to  $f'_c = 5000$  psi. Concrete capacity values may be modified by  $\sqrt{f'_c/5,000}$  psi, **but  $V_n$  must not exceed the bearing angle's steel capacity of 42.1 kips.** Steel capacity includes  $\Phi = 0.90$
- C. Capacity values for concrete failures may be increased by adding additional reinforcing, (Reference ACI 318-14 Section 17.4.2.9 and 17.5.2.9), **but  $V_n$  must not exceed the bracket's steel capacity of 42.1 kips.**
- D. Tested values  $N_u$  are based on 12.5% of  $V_u$ . The test loads were applied simultaneously
- E. **For conditions not covered within the tabulated values, connection capacities may be determined using appropriate stud design software or in accordance with the provisions of ACI 318. In all cases, the calculated capacity shall not exceed the steel capacity of 42.1 kips.**

# RLU Reinforcement Recommendations

## Anchor Reinforcement per ACI 318

For conditions where the factored shear loads exceed the published values, it is permitted to increase the capacity per ACI 318 utilizing anchor reinforcement, not to exceed  $\Phi V_n=42.1$  kips for the RLU-8, RLU-10 series & not to exceed  $\Phi V_n=18.6$  kips for RLU-M series. A minimum edge distance of 9in should be maintained to the center of the exterior studs to not compromise the projected tension breakout cone.

Anchor reinforcement shall consist of a #6 ASTM A615 Gr 60 rebar. To ensure yielding of the anchor reinforcement, the hair pin should be in contact with the anchors and placed as close as possible to the surface of the concrete. Contact [engineering support@leviat.us](mailto:engineering support@leviat.us) if you have any questions or need any assistance.

Rebar Detail A: RLU-8 & RLU-10

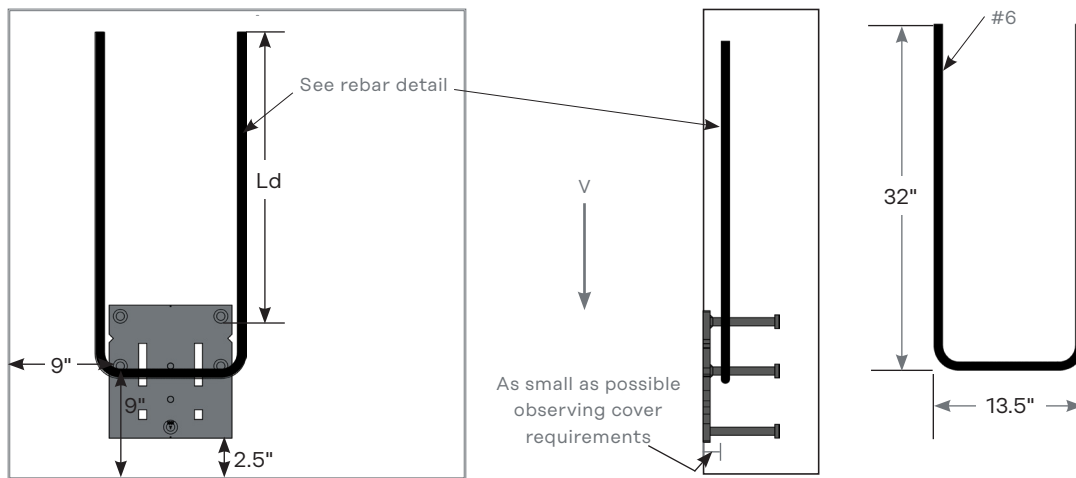

**NOTE:** Rebar development length based on 5000psi NWC

## Lite Wall Applications

Leviat's RLU system is an ideal solution to support double tees in lite walls. The capacities provided for Condition BES 2 should be utilized and are based on testing in a 24" wide section (Detail A). In a lite wall condition for ramps, the RLU can accommodate up to a 20% slope with no reduction in capacity per Condition BES 2 (Detail B). For widths less than 24in it is permitted to analyze using a stud software or utilize anchor reinforcement per ACI 318.

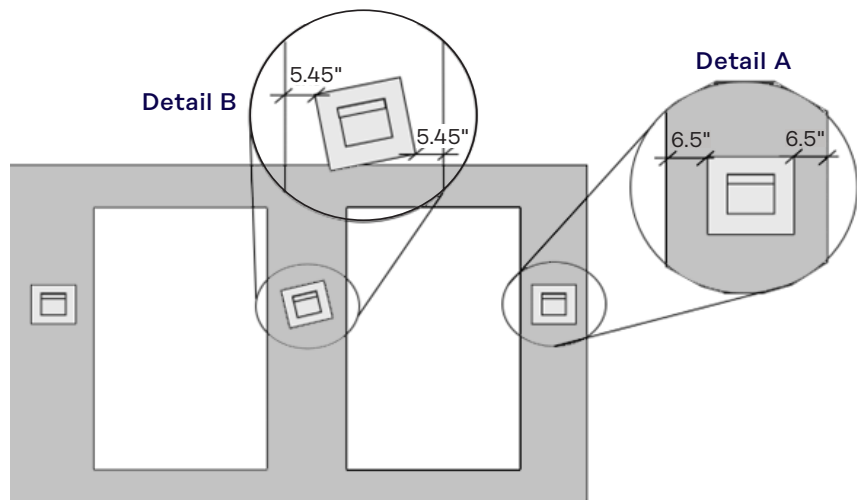

# RLU-M Panel Fully Supported at Bottom

Wall, Lite Wall, Column

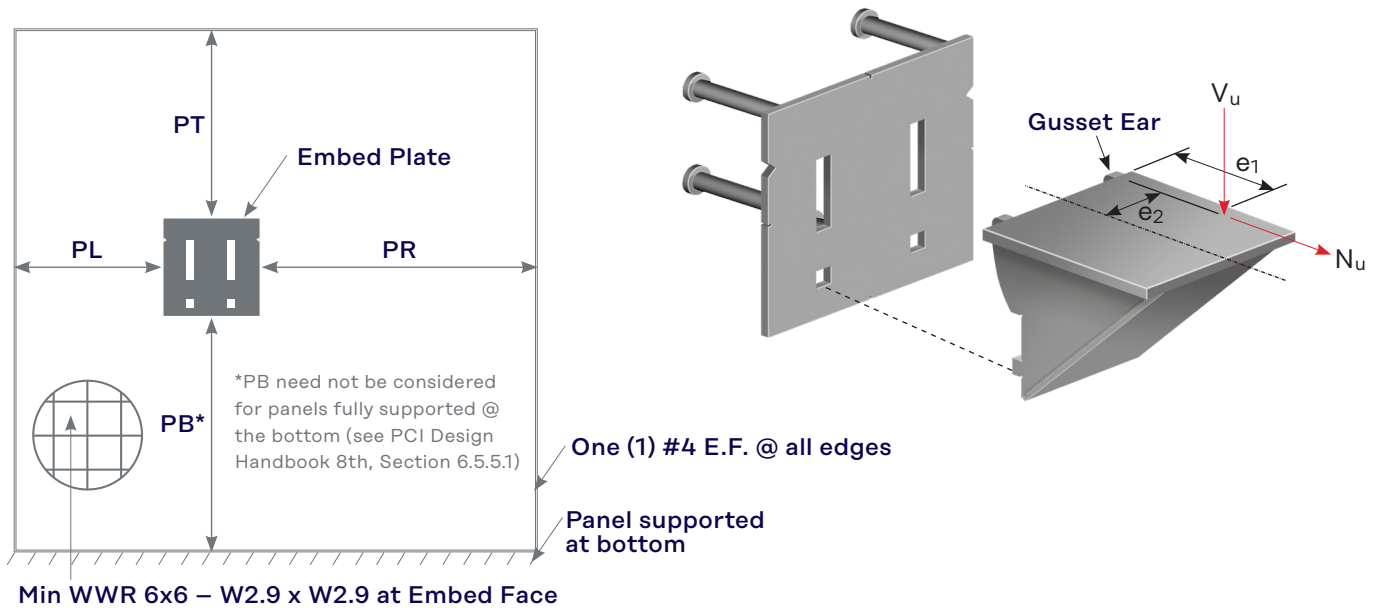

## RLU-M Capacities

Table values are based on physical tests using ACI's 5% Fractile Analysis and ACI 318 calculations. **Minimum member thickness = 8"**

1. Tabulated capacities must be coordinated with applicable support conditions
2. Tables are only to be used by qualified structural engineers who understand and apply all applicable codes
3. Table values apply to fully factored ultimate loads ( $V_u$  and  $N_u$ )

Condition	Description	PL	PR	PT	PB	2-Hour Fire Rating ASTM E119 $V_{service} = 7.5\text{kips}$ $e_1 \leq 3"$			No Fire Rating $e_1 \leq 3"$		
						$\Phi V_n^{a,e}$	$\Phi N_n^{a,d,e}$	Failure Mode <sup>o</sup>	$\Phi V_n^{a,b,c}$	$\Phi N_n^{a,b,c,d}$	Failure Mode
BES 1	Free edge on one side	$\geq 8.5$	$\geq 0.0$	$\geq 17.0$	N/A	10.0 kips	1.3 kips	N/A	18.6 kips	2.3 kips	Steel
BES 2	Free edge on one side & Top edge (Top Corner)	$\geq 8.5$	$\geq 0.0$	$\geq 5.0$	N/A	10.0 kips	1.3 kips	N/A	12.9 kips	1.6 kips	Concrete
BES 3	Top edge	$\geq 8.5$	$\geq 8.5$	$\geq 5.0$	N/A	10.0 kips	1.3 kips	N/A	18.6 kips	2.3 kips	Steel

- A. Capacity values table BES use a  $\Phi$ -factor = 0.70. If the structural engineer determines a  $\Phi = 0.75$  may be used, then the table values may be multiplied by a factor =  $(0.75/0.70) = 1.071$ , **but  $\Phi V_n$  must not exceed the bearing angle's steel capacity of 18.6 kips.**  
 Typical ACI 318 -factors are: (Reference ACI 318-14 Section 17.3.3)  
 $\Phi$ -factor = 0.70 for members without confinement reinforcing  
 $\Phi$ -factor = 0.75 for members with adequate confinement reinforcing
- B. All values apply to  $f'_c = 5000$  psi. Concrete capacity values may be modified by  $\sqrt{f'_c/5000\text{ psi}}$ , **but  $V_n$  must not exceed the bearing angle's steel capacity of 18.6 kips.** Steel capacity includes  $\Phi = 0.90$
- C. Capacity values for concrete failures may be increased by adding additional reinforcing, (Reference ACI 318-14 Section 17.4.2.9 and 17.5.2.9), **but  $V_n$  must not exceed the bracket's steel capacity of 18.6 kips.**
- D. Tested values  $N_u$  are based on 12.5% of  $V_u$ . The test loads were applied simultaneously
- E. Design load capacity limited by Fire Test load  $V_{service} = 7.5$  kips
- F. **For conditions not covered within the tabulated values, connection capacities may be determined using appropriate stud design software or in accordance with the provisions of ACI 318. In all cases, the calculated capacity shall not exceed the steel capacity of 18.6 kips.**

# RLU-M Panel with Free Edge at Bottom

## Spandrel, Wall Opening with Below

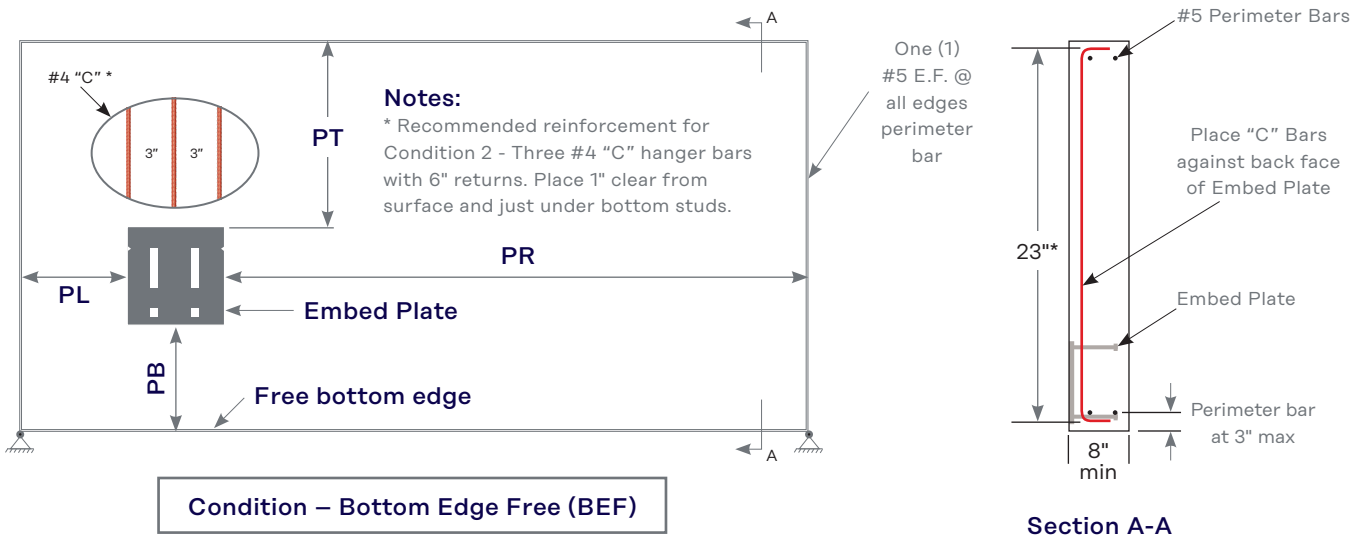

### RLU-M Capacities

Table values are based on physical tests using ACI's 5% Fractile Analysis and ACI 318 calculations. **Minimum member thickness = 8"**

1. Tabulated capacities must be coordinated with applicable support conditions
2. Tables are only to be used by qualified structural engineers who understand and apply all applicable codes
3. Table values apply to fully factored ultimate loads ( $V_u$  and  $N_u$ )

Condition	Description	PL	PR	PT	PB	2-Hour Fire Rating ASTM E119 $V_{service} = 7.5$ kips $e_1 \leq 3"$			No Fire Rating $e_1 \leq 3"$		
						$\Phi V_n^{a,e}$	$\Phi N_n^{a,d,e}$	Failure Mode <sup>e</sup>	$\Phi V_n^{a,b,c}$	$\Phi N_n^{a,b,c,d}$	Failure Mode
Condition 1 Unreinforced	BEF 5 Spandrel - Bottom edge	$\geq 15.0$	$\geq 15.0$	$\geq 9.0$	$\geq 1.0$	3.7 kips	0.5 kips	Concrete	3.7 kips	0.5 kips	Concrete
Condition 2 Reinforced <sup>f</sup>	BEF 6 Spandrel - Bottom edge	$\geq 15.0$	$\geq 15.0$	$\geq 9.0$	$\geq 1.0$	10.0 kips	1.3 kips	N/A	18.6 kips	2.3 kips	Steel

- A. Capacity values Condition 1 use a  $\Phi$ -factor = 0.70. If the structural engineer determines a  $\Phi = 0.75$  may be used, then the table values may be multiplied by a factor =  $(0.75/0.70) = 1.071$ , **but  $\Phi V_n$  must not exceed the bearing angle's steel capacity of 18.6 kips.**  
 Typical ACI 318 -factors are: (Reference ACI 318-14 Section 17.3.3)  
 $\Phi$ -factor = 0.70 for members without confinement reinforcing  
 $\Phi$ -factor = 0.75 for members with adequate confinement reinforcing  
 Capacity values Condition 2 use a  $\Phi$ -factor = 0.75 due to use of confinement reinforcement.
- B. All values apply to  $f'_c = 5000$  psi. Concrete capacity values may be modified by  $\sqrt{f'_c/5,000 \text{ psi}}$ , **but  $V_n$  must not exceed the bearing angle's steel capacity of 18.6 kips.** Steel capacity includes  $\Phi = 0.90$
- C. Capacity values for concrete failures may be increased by adding additional reinforcing, (Reference ACI 318-14 Section 17.4.2.9 and 17.5.2.9), **but  $V_n$  must not exceed the bracket's steel capacity of 18.6 kips.**
- D. Tested values  $N_u$  are based on 12.5% of  $V_u$ . The test loads were applied simultaneously
- E. Design load capacity limited by Fire Test load  $V_{service} = 7.5$  kips
- F. Increased capacities based on reinforcement calculations per ACI 318
- G. **For conditions not covered within the tabulated values, connection capacities may be determined using appropriate stud design software or in accordance with the provisions of ACI 318. In all cases, the calculated capacity shall not exceed the steel capacity of 18.6 kips.**

# MB Rapid-Lok Ultimate Saddle

The ultimate alternative to ledges and dapped tee construction

## Overview

Leviat's MB Rapid Lok Ultimate Saddle is an engineered steel saddle system that provides a permanent, durable, easy-to-install replacement to the traditional concrete ledge and dapped double tee construction method.

Rapid-Lok Ultimate Saddle is designed to support double tees in spandrels and walls without requiring dapping the double tee or forming ledges in the panel.

Installation is safe and simple. The Embed Plate is cast into the concrete panel at the precast plant with face flush to the wall surface. Once the unit is on-site, the attached void formers are removed from the face of the embed plate to reveal recesses. The Bearing Saddle ears are then engaged into the recesses of the Embed Plate, securely locking the entire assembly into place without requiring a weld.

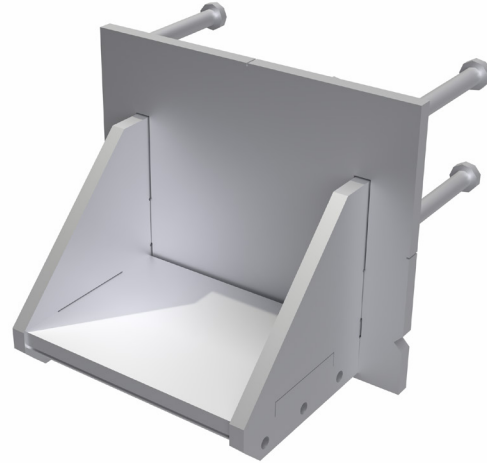

## Features

- **Benefit:** Eliminates need to dapped tees: Permits use of standard double tee beams at spandrels and openings.
- **Benefit:** Reduces complex rebar detailing of panel and double tee: Casting traditional ledges and dapped double tees require costly specialized equipment, forms and additional reinforcement detailing
- **Benefit:** Permits use of standard panels with no irregular shapes: Simplifies production, storing and shipping walls and spandrels by removing protruding elements.
- **Benefit:** Eliminates obstacles when erecting: No protruding elements to maneuver double tees around, provides straight drop in path for beam placement.



# MB Rapid-Lok Ultimate Saddle

The ultimate alternative to ledges and dapped tee construction

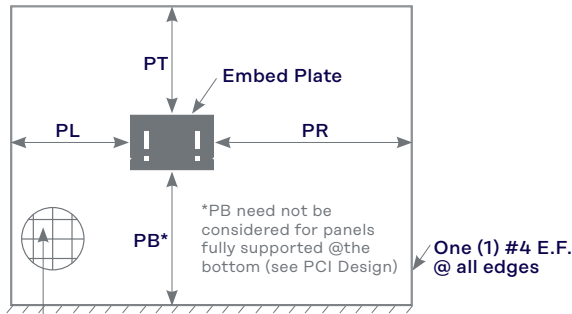

Min WWR 6x6 – W2.9 Embed Face

Condition – Bottom Edge Supported (BES)

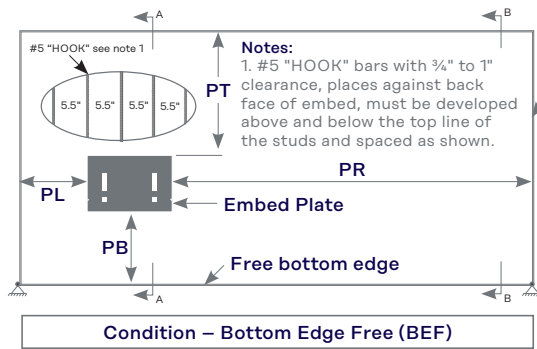
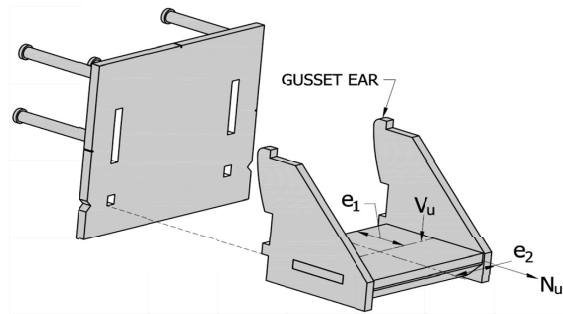

Condition – Bottom Edge Free (BEF)

One (1) #5 E.F. @ all edges perimeter bar

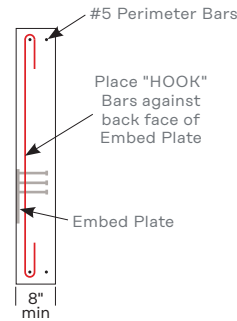

Section A-A

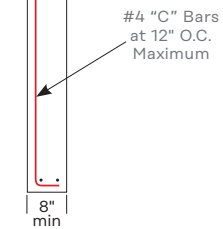

Section B-B

## RLU-SA-10 Capacities

Table values are based on physical tests using ACI's 5% Fractile Analysis and ACI 318 calculations. **Minimum member thickness = 8"**

1. Tabulated capacities must be coordinated with applicable support conditions
2. ASTM E119 fire duration for all assemblies is 1 hr with  $V_{service} = 25$  kips
3. Tables are only to be used by qualified structural engineers who understand and apply all applicable codes
4. Table values apply to fully factored ultimate loads ( $V_u$  and  $N_u$ )

							RLU-SA-10 $e_1 \leq 6"$ and $e_2 \leq 2"$		
Condition		Description	PL	PR	PT	PB	$\Phi V_{nf}^{a,b,c}$	$\Phi N_{nf}^{a,b,c,d,e}$	Failure Mode
Unreinforced	BEF 1	Side edge	$\geq 7.25"$	$\geq 9.0"$	$\geq 9.0"$	N/A	50.4 kips	6.3 kips	Steel
Reinforced with (4) #4 "HOOK" Bars	BEF 2	Side Edge - Bottom edge	$\geq 10.5"$	$\geq 17.0"$	$\geq 16.0"$	$\geq 0.0"$	44.1 kips	5.5 kips	Concrete

- A. Capacity values Condition 1 use a  $\Phi$ -factor = 0.70. If the structural engineer determines a  $\Phi = 0.75$  may be used, then the table values may be multiplied by a factor =  $(0.75/0.70) = 1.071$ , **but  $\Phi V_n$  must not exceed the bearing angle's steel capacity of 50.4 kips.**  
Typical ACI 318 -factors are: (Reference ACI 318-14 Section 17.3.3)  
 $\Phi$ -factor = 0.70 for members without confinement reinforcing  
 $\Phi$ -factor = 0.75 for members with adequate confinement reinforcing
- B. Capacity values for Condition 2 use a  $\Phi$ -factor = 0.75 due to use of confinement reinforcement.
- C. All values apply to  $f'_c = 6000$  psi. Concrete capacity values may be modified by  $\sqrt{f'_c/6,000\text{psi}}$ , **but  $V_n$  must not exceed the bearing angle's steel capacity of 50.4 kips.** Steel capacity includes  $\Phi = 0.90$
- D. Capacity values for concrete failures may be increased by adding additional reinforcing, (Reference ACI 318-14 Section 17.4.2.9 and 17.5.2.9), **but  $V_n$  must not exceed the bracket's steel capacity of 50.4 kips.**
- E. Tested values  $N_u$  are based on 12.5% of  $V_u$ . The test loads were applied simultaneously.

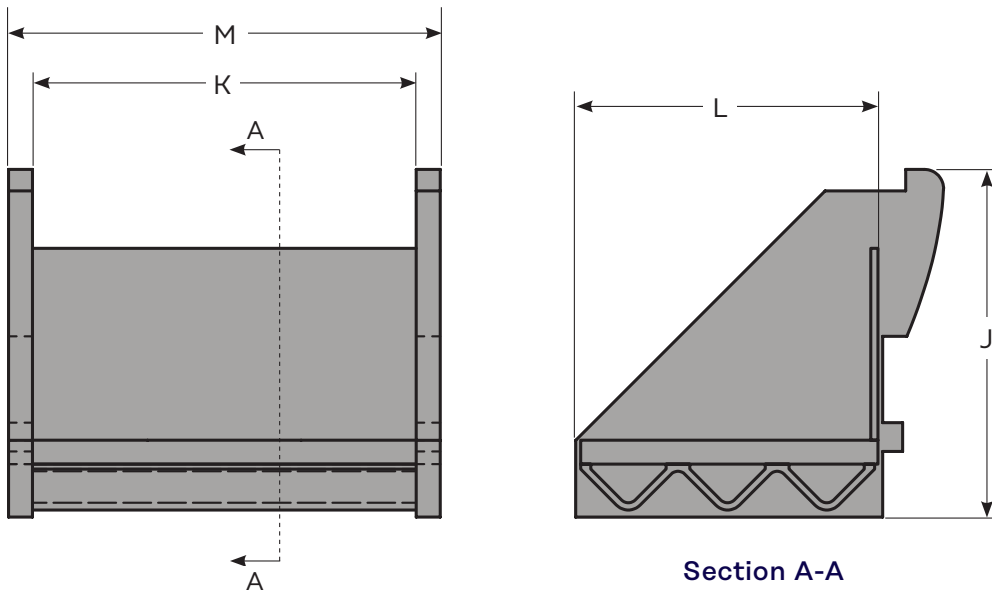
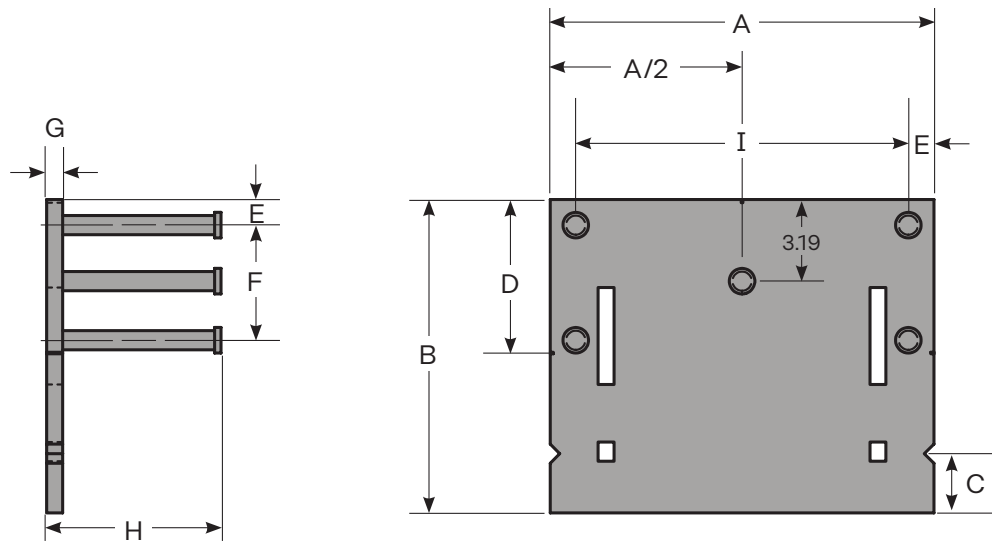

### Dimensions - Embed Plate

Product	Item Number	A	B	C*	D	E	F	G	H	I	Number of Studs	Stud Size	Weight
RLU-S-10	MBRLUSP10G	15"	12.25"	2.32"	6"	1"	4.5"	0.63"	6.82"	13"	5	0.75"x6.19"	38 lbs

\*Tri-cut at dimension C indicates the bearing surface of the angle.

### Dimensions - Bearing Angle

Product	Item Number	J	K	L	M	Weight
RLU-S-10	MBRLUSA10G	9.1"	10"	7.75"	11.25"	44 lbs

# Installation Instructions

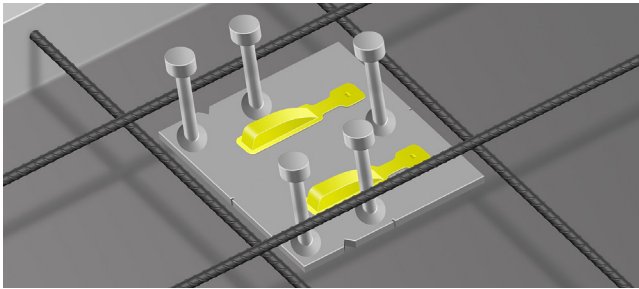

## Down-in-Form Embed Plate Installation

- Place the face of the Embed Plate upon the base of the casting bed, aligning the Tri-Cut to the correct bearing elevation of where the stem of the double tee or concrete element will sit
- Secure Embed Plate in place
- Caulk around the base of the Embed Plate to avoid concrete leakage underneath
- The plastic void formers cause the face of the embed plate to be approximately 1/8" off the form face
- Finish preparing the panel and pour concrete

**WARNING: TO AVOID DAMAGE, DO NOT PLACE REINFORCING ON TOP OF VOID FORMERS**

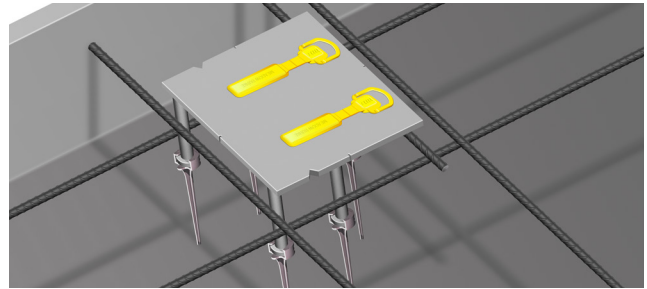

## Up-in-Form Embed Plate Installation

- Attach Stud Extenders to the Embed Plate Round Head Studs. If necessary, adjust the height by cutting the legs of the Stud Extender to ensure the face of the Embed Plate lies flush to the panel surface
- Place the Round Head Studs down and position in the casting bed aligning the Tri-Cut to the correct bearing elevation where the double tee or concrete element will sit
- Secure Embed Plate to the rebar cage
- Finish preparing the panel and pour concrete

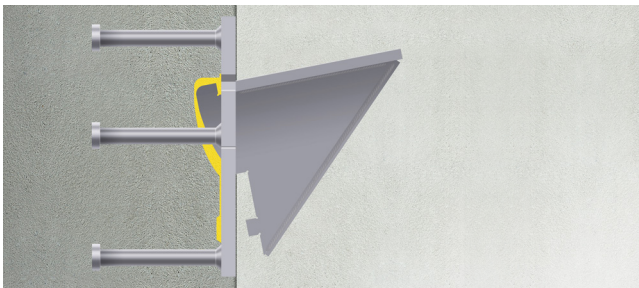

## Bearing Angle Installation

- Prior to wall erection remove the plastic void former cover by pulling the plastic tabs
- Leading with the front of the Bearing Angle Ears, using a slotting motion, engage the Ears of the Bearing Angle into the Rectangular Openings of the Embed Plate
- Seat the bottom Square Posts of the Bearing Angle into the Square Openings of the Embed Plate
- The Rapid-Lok Ultimate is now ready for the double tee to be erected and placed upon the shelf of the Bearing Angle



# Rapid-Lok Ultimate Bearing Angle Retention Wedge

Simple securing of Rapid-Lok Ultimate components

## Overview

The Rapid-Lok Bearing Angle Retention Wedge provides a temporary method to reduce the risk of pre-installed bearing angles from disconnecting from concrete panels during handling and transit.

## Product Data - Rapid-Lok Bearing Angle Retention Wedge

Item	Bundle Quantity	Carton Quantity
MBRLU-WDG	36	576



## Installation Guide



**1.** With the ribs of the retention wedge towards the embed plate, slide the thin end into the gap between the embed plate and bearing angle near the outer edge. Repeat the process using a second wedge at the opposite side of the bearing angle.



**2.** Using a small wooden block and hammer, tap the top of wedges down into the gap until they are both firmly seated.



**3.** After transporting the panels and placing, the wedges can be left in place or broken off flush with the bearing angle by simply pulling them towards the front of the bearing angle and down to the bearing angle face.

## Wedge Removal

If removal is necessary, prior to breaking wedge flush, the retaining wedge can be completely removed by grabbing its top with pliers and pulling upward while simultaneously

pulling in a side-to-side motion in line with the embed plate to dislodge. Removal after breaking flush with bearing plate requires using a thin profile tool, such as piece of  $\frac{1}{8}$ " thick bar steel

or standard blade screw driver, and driving wedge deeper into gap until it clears the bearing angle.

# Rapid-Lok Ultimate Stud Extender

## Product Data - Stud Extender

Item Number	Size	A	B	C	Weight
<sup>1</sup> MB291833	3/4"	1 1/4" Head	1 5/8"	1"	0.192 oz
<sup>2</sup> MB291834	3/4"	1 1/4" Head	3 5/8"	3"	0.240 oz
<sup>3</sup> MB291832	1/2"	1" Head	5 3/4"	5 1/4"	0.245 oz
<sup>3</sup> MB291830	3/4"	1 1/4" Head	5 7/8"	5 1/4"	0.275 oz

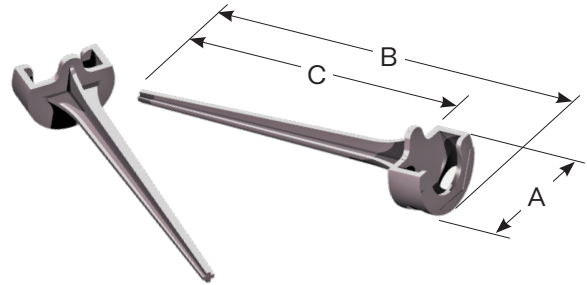

1. Suitable for 8" panels thickness
2. Suitable for 10" panels thickness
3. Cut to fit panel thickness

## Overview

The RLU Stud Extender is designed as an adjustable height support chair for embed/weld plates. The Stud Extender eliminates the tedious, labor-intensive wood forming or risky "wet setting" of embed plates in the top-face of a concrete panel.

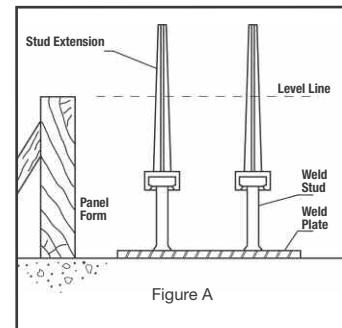

## Installing the Stud Extender on an Embed or Weld Plate (Figure A)

- Press the MB Stud Extender onto the head of the weld stud
- Place the weld plate next to the panel form
- Run a level line from the top of the form across the Stud Extenders
- Cut off the MB Stud Extender at the level line

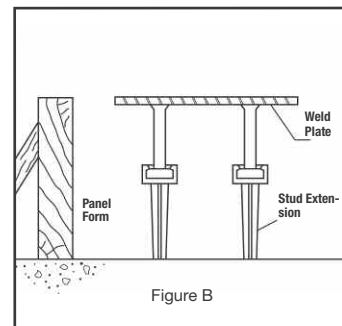

## Installing the Embed Plate or Weld Plate in the form (Figure B)

- Turn the weld plate upright and place in the proper position
- Secure the weld plate studs to the rebar mat or edgeform

## NOTES:

- This product comes in two different sizes: 1" and 1 1/4", which are the two most common button sizes used on studs in the field and adds up to 5" to the length of the stud. This product is ideal for insulated panels. By adding the thickness of the insulation, the stud extension simply sticks down through the foam, increasing the stability of the Stud Extender.
- Generally, each weld plate must have at least four (4) Stud Extenders.
- Large weld plates may require additional Stud Extenders to support the weight.

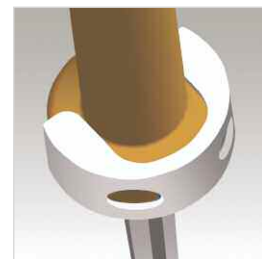

# Notes

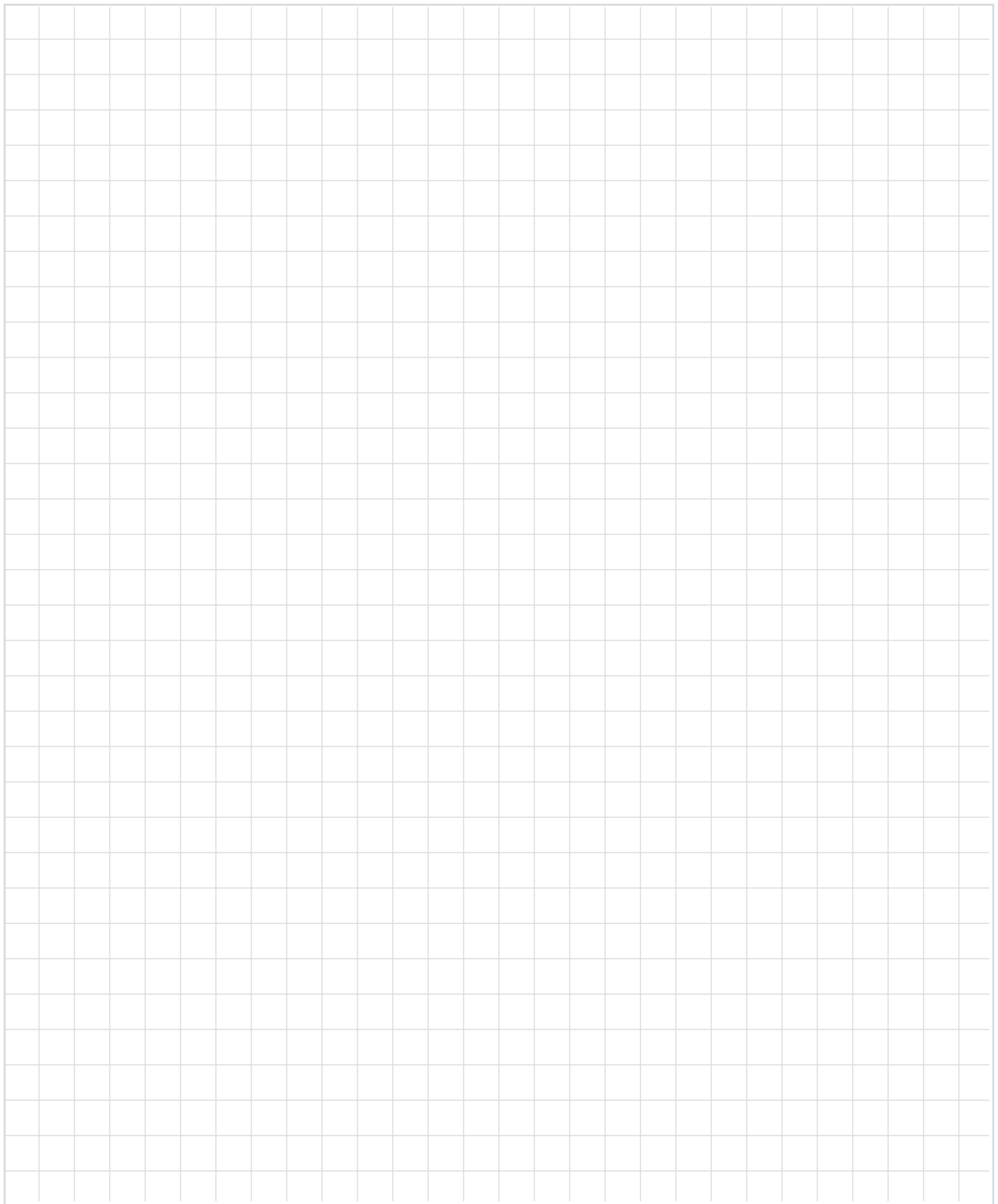

## North American Locations

### California

3611 E La Palma Ave  
Anaheim CA 92806

**Florida** Corporate  
6467 S Falkenburg Road  
Riverview FL 33578

**Georgia**  
3080 N Lanier Parkway  
Decatur GA 30034

### Iowa

1000 Technology Drive  
Boone IA 50036

**Oregon**  
155 SE Hazel Dell Way  
Canby OR 97013

### Pennsylvania

565 Oak Ridge Road  
Hazle Township PA 18202

**Texas**  
6500 N Interstate 35  
San Antonio TX 78218

## Contact Information

### Customer Service

(844) 453-8428 | 844-4-LEVIAT

### Engineering Support

(813) 212-5866

### Email

contactus@leviat.us

## Leviat.com

For information on certified management systems and standards see [www.meadowburke.com](http://www.meadowburke.com) | [www.halfen.com](http://www.halfen.com) | [www.thermomass.com](http://www.thermomass.com)

### Notes regarding this catalogue

© Protected by copyright. The construction applications and details provided in this publication are indicative only. In every case, project working details should be entrusted to appropriately qualified and experienced persons. Whilst every care has been exercised in the preparation of this publication to ensure that any advice, recommendations or information is accurate, no liability or responsibility of any kind is accepted by Leviat for inaccuracies or printing errors. Technical and design changes are reserved. With a policy of continuous product development, Leviat reserves the right to modify product design and specification at any time.

Imagine. Model. Make.